

HARLO®

HP6500 ROUGH TERRAIN FORKLIFT - 4WD



HARLO – since 1958 – The Industry Leader in Rough Terrain Forklifts Versatile & Innovative

HARLO earned the coveted reputation for manufacturing robust and reliable forklifts. Our forklifts are designed for rough terrain and have the reputation of providing results in tough conditions. You'll be hard-pressed to find anything else that can stand up to or even come close to a **HARLO**. The **HP6500** is the workhorse of the product line. With a large range of mast heights and configurations, the size and shape of the load is endless.

Standard Options

When you want the fastest on the job site at **27.4 mph**, or utilizing our **generous 35 GPM main pump** to lift at **96.3 fpm (15' 2 stage mast)** and **144.4 fpm (22' 3 stage mast)**, multitasking with amazing agility at **11.5" of ground clearance**, turning at a **10'7" radius**, **HARLO** is second to none! The internal wet brake and holding brake give stopping and holding power for all applications.

Exceptional Features

Smooth shifting is accomplished with our 4-speed manual transmission. Standard mast options of 15' two-stage and 22' three-stage lift your load with ease. The Cummins 74HP Diesel engine is low maintenance, fuel efficient, provides plenty of power, and has faster response times.

HP6500 Rough Terrain Forklift Specifications

Engine

Model	Cummins QSF3.8L
Type	Tier 4 Final Emission Certified
Cylinders	4 Cycle Turbocharged Diesel
Displacement	4
Fuel Injection	229 CID
Fuel	Bosch Electronic
Tank Capacity	Ultra Low Sulfur Diesel
Cooling	24 Gallons
Max Speed (eng)	Liquid Cooled
Idle Speed (eng)	2200 RPM
Horse Power	800 RPM
Maximum Torque	74 HP @ 2200 RPM
Water Pump Style	295 ft/lb @ 1300 RPM
Engine Oil	Integral
	SAE 15-W40



Mast

Forward Tilt	34 Degrees
Backward Tilt	10 Degrees
Side Shift	6" Total - 3" Left / 3" Right
Load Cushioning	Optional Accumulator

Tires

Front	16.9 - 24 (12 Ply)
Rear	12 - 16.5 (10 Ply)

Mast Configurations

Lift Height	Carriage Type	Carriage Width	Stages	Lowered	Extended	Capacity @ 24" Load Center	4WD Weight
15' Roller	ITA or Swing	60", 72", 84", 96"	2	125"	212"	6500lbs to 15'	13,400 lbs
22' Roller	ITA or Swing	60", 72", 84"	3	125"	300"	6500lbs to 12' 4500lbs to 15' 2500lbs to 22'	14,000 lbs

Electrical

Voltage	12 Volts
Alternator	135 Amps
Battery	2 @ 950 CCA
Power Plugs	12V (Single) USB (Dual)



Warning Lights

Engine Oil Pressure - Transmission Oil Temperature - Air Cleaner Restriction
Alternator Charge - Engine Water Temperature - Parking Brake
Fuel Level - Engine Preheat

Audible Alarm

Backup Alarm - HORN

Operator Environment

Standard Safety: Adjustable Seat Cushion – Rear View Mirror – Seatbelt – FOP Overhead Guard – See-thru Mast – A.N.S.I. B56.6 Safety Compliant

Gauges

Fuel Level – Hour Meter – Voltmeter – Coolant Temperature

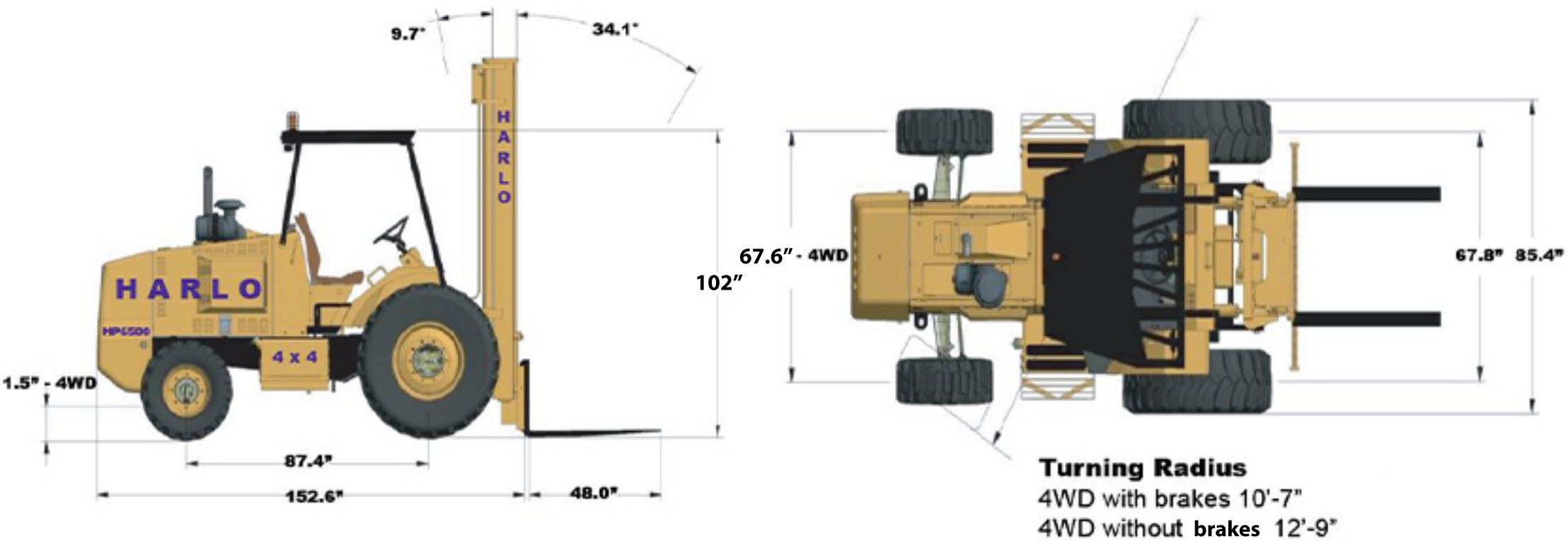

Harlo.com

Harlo Facebook

